

Typical applications illustrating the correct ways of applying the Support Components in the STC Chimney Range where applied internally. Please use in conjunction with the STC Chimney Installation Instructions.

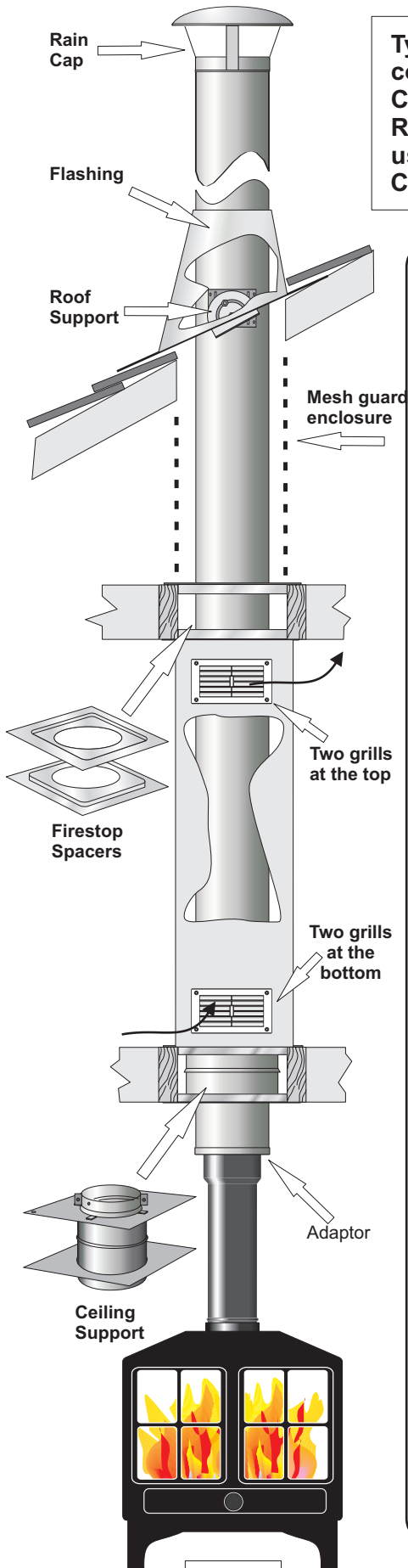

Figure 1

Free Standing Solid Fuel appliance. Method 1. With grill ventilated enclosure

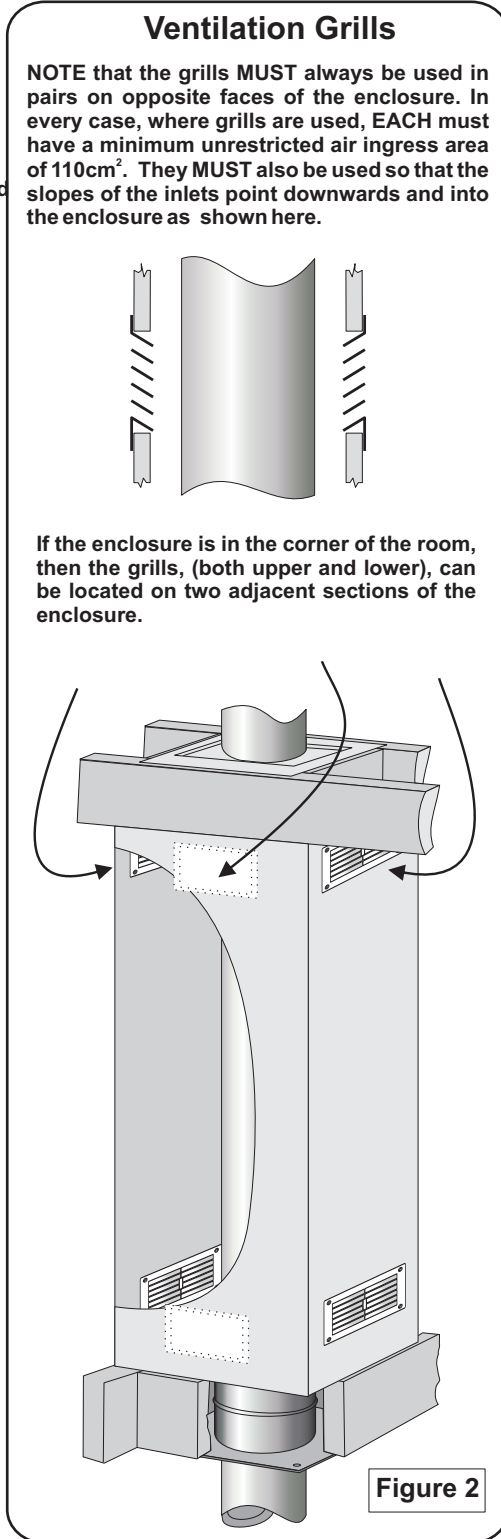

Figure 2

See side two for external application illustrations as well as Installation Guidance.

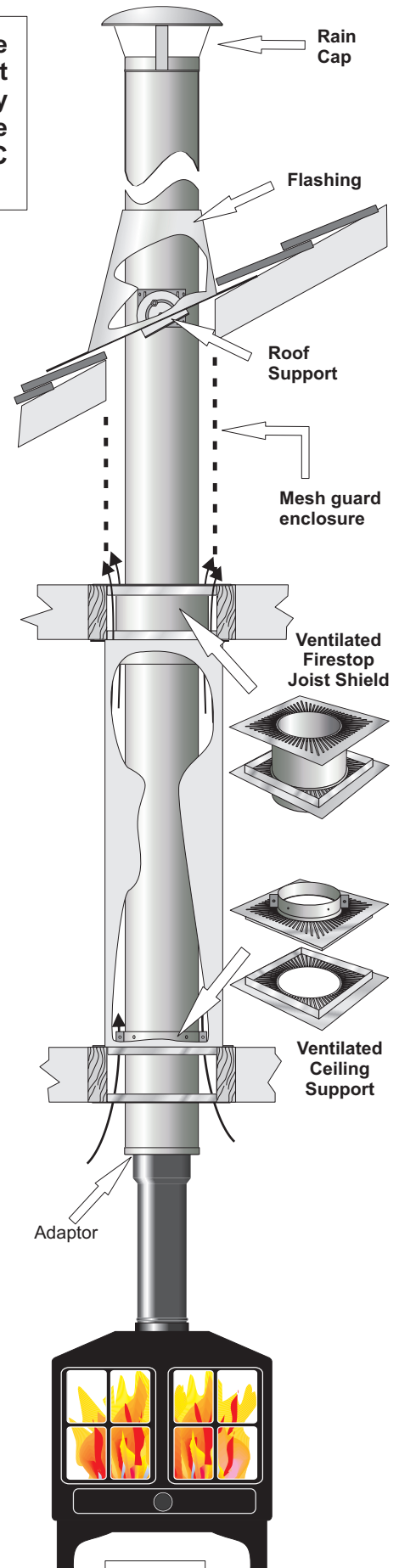

Figure 3

Free Standing Solid Fuel appliance. Method 21. With Ventilated Supports.

General guidance for the Installation of the Selkirk STC Chimney System (continued)

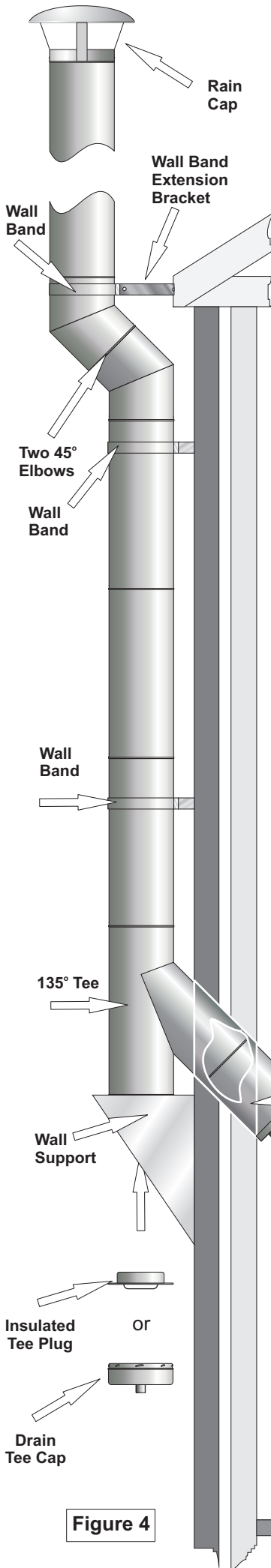

Figure 4

Chimney Route and Diameter

The chimney should preferably rise vertically from the appliance to the termination outlet. However, as that is not always practical, changes of direction can be made, provided that no part of the chimney route exceeds an angle greater than 45° from the vertical. To ensure adequate performance, we recommend that any inclined sections do not exceed 20% of the total length of the chimney run. No joint between chimney sections is permitted within the thickness of a wall or floor. An exception would be where a short length and the branch of a 45° Tee connect within an external wall thickness. The use of a metal Wall Sleeve encasing the joint at this point is usually acceptable, particularly as it also eases installation and maintenance.

To prevent soot or fly ash dangerously blocking a flue ways, Building Regulations will not permit any part of the flue system, including a connecting flue pipe, to run horizontally for a distance greater than 150mm. Whatever the configuration, a minimum 600mm vertical rise of the flue or chimney from the appliance outlet is advised so to avoid initial draught restriction. The appliance manufacture may also dictate minimum requirements in this respect.

The chimney diameter should never be less than the diameter of the exit spigot on the appliance. The appliance manufacture's instructions may dictate a larger diameter.

Proximity to Combustible Materials

A minimum air gap distance of 50mm MUST be maintained from the outside surface of the chimney to any combustible material by using the dedicated supports and components provided for the STC Chimney System. The use of any additional insulation to avoid this requirement can be dangerous as the heat radiation characteristics will alter. Where passing through a cupboard or roof space, a non-combustible shield must be constructed to surround the chimney providing a 50mm minimum air gap clearance to any combustible material - including any materials which may be subsequently stored within these areas. Metal mesh would normally fulfill this requirement.

Building Regulations dictate that flue pipes connecting the appliance to the chimney MUST do so within the room containing the appliance. Flue pipes MUST also have their external surfaces clear of any combustible material by a minimum distance of at least three times the diameter of the flue pipe. That clearance can be halved if a heat shield is used which is at least 12mm clear of the combustion material being protected.

Support

The chimney must be adequately supported and braced using the dedicated supports and components provided for the STC Chimney System and applied in accordance with the Instructions provided. The full weight of the chimney must be borne by these dedicated components and no weight should be taken by the appliance it serves. Support and/or horizontal bracing must be applied at intervals not exceeding 2.5m. The use of any other support process will result in non-compliance with Building regulations and the STC Chimney's Approval Status.

Combustion Air Provision

Building Regulations require that all combustion appliances with an output exceeding 5kW are provided with a permanent dedicated opening through which air for combustion can freely pass. It is incumbent on the chimney and appliance installer to check with current legislation to ensure that the requirements are met. Failure to provide combustion air is not only dangerous, its inadequate provision can, via the process of incomplete combustion, result in excessive soot production and subsequent operation and maintenance problems.

Maintenance Facilities

Provision must be made for cleaning and maintenance of flue pipe and the chimney. The Drain Tee Cap or the Insulated Tee Plug provide access as would access covers plates in connecting flue pipes.

Flue termination requirements for solid fuel and wood burning appliances

The table and illustration shown in Figure 5 detail the minimum requirements for termination as required by Building Regulations. In each case, "termination" refers to the point at the top of the chimney flue outlet from which products of combustion are discharged from the flue. Any rain cap or other termination device is not included. It must be stressed that these are minimum discharge heights and relate to safety relative to potential human or fire hazard. The discharge requirements do not guarantee that the chimney will perform as required. There are so many other factors which can have a detrimental impact on the way the chimney performs. Taller nearby structures - buildings and trees, local topography and even other operating chimneys in the same building can all influence and sometimes interfere with the way a chimney operates.

Notification Plate

On completion of the installation, Building Regulations require that a "Notice Plate for Hearths and Flues" must be completed and dated and be permanently "fixed" in the building in a convenient location where it can be seen by interested persons relative to flue/appliance suitability and maintenance. Close to a service meter or the heating appliance is considered to be a convenient location. **Selkirk can provide Notice Plates on request.**

Distance	Minimum distance measured from the top of the chimney construction, excluding any pot or terminal.
A	2.3 metres horizontally clear of the roof surface, eg. if the roof pitch is 45°, then the chimney should project 2.3 metres above it.
B	1 metre, provided A is satisfied, or 600mm above the ridge if G is less than 600mm.
C	1 metre above the top of any flat roof, and the top of any openable roof light, dormer window or ventilator, etc., if it is located within 2.3 metres.
D/E	If D is less than 2.3 metres, E shall be not less than 600mm.
F	600mm above the ridge.

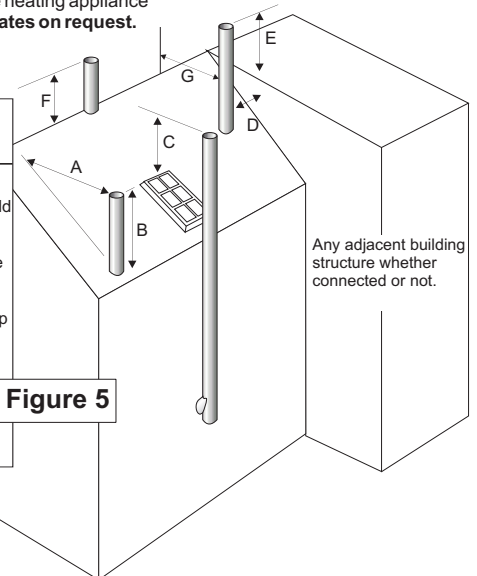

Figure 5

For more information on twinwall systems, or to purchase twinwall supplies. Please go to :

<http://www.oilstoves.co.uk/flue.php?TwinWall>

For further information please contact: