



The solid fuel corner stove is an extension to the corner oil stove. The stove has been designed specifically for use on Narrow Boats and its triangular shape makes it suitable for fitting into corner locations. In its solid fuel set up it can burn logs as well but to set up the stove as

an out and out wood burner the additional wood grate should be fitted. The stove can be supplied as a water heater with a fully integral high output boiler and a water temperature sensing thermostat. *Silent simplicity just for you.*

## Features

- Triangular construction creates the most economical use of space.
- Fully adjustable door hinges and locks.
- Stay cool easy to use door handle.
- Stainless steel grate carrier, front fret and grate.
- The high chrome content of the stainless steel grate gives a much longer life.
- Deep ash pan, capable of holding 24 hours of burnt ash.
- Deep combustion chamber capable of holding a large fuel load.
- Three controlled air routes into the stove.
- Water heating options available.
- Built in heat shields to reduce radiation
- Optional thermostatic water temperature control.
- The thermostat will save fuel and create consistent steady temperatures.
- Designed and manufactured in the U.K.

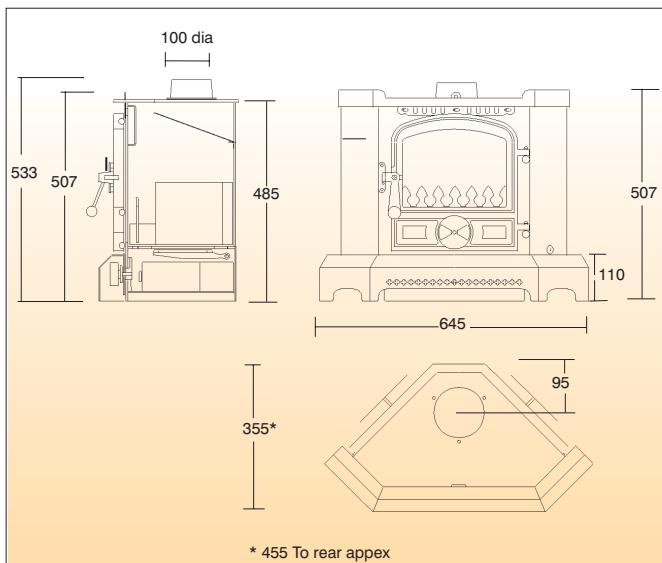

**To ensure performance as specified, Bubble stove must be installed by competent persons.**

Flame effect may differ from photographic representation on this brochure.



Harworth Heating Limited,  
Blyth Road, Harworth, Doncaster, South Yorkshire DN11 8NE.  
Tel: 01302 742520 3 lines Fax 01302 750573  
www.oilstoves.co.uk Sales@oilstoves.co.uk



**FLEX A FLAME CONVERTA KIT**



Your Local Dealer