



BUBBLE PRODUCTS

BOAT CHIMNEYS AND FLUE SYSTEMS

LIVE ABOARD AND LEISURE BOATING

MODELS FOR ECONOMIC AND PRACTICAL BOAT HEATING SYSTEMS

<http://www.oilstoves.co.uk/>

1. INTRODUCTION.

What a dilemma, boats are becoming more and more sophisticated and in many areas pushing technology to it's limit.

Wireless internet, autonomous energy systems, fully automatic heating systems and now a new family of swim designs which can dramatically reduce the required propulsion power, L.E.D. lighting, Solar and Photovoltaics, it goes on and on but there is a but and it's a big but.

Traditional above deck chimney's fitting on cast iron deck flanges, designed 100 years ago and still being used, this is Neolithic technology and in the constant drive for improvements, has been rather sadly neglected.

At Bubble, we have tried to do our bit by improving the design of the deck flange and providing copious amounts of info via our technical and user booklets supplied with our products and also posted on our web site www.oilstoves.co.uk.

There is still a long way to go and we intend to carry on with our innovative improvements in this area.

Boats with all the nice features are now beginning to mimic modern houses and the ability to do this has been brought about by the massive improvements of on board electrical systems.

As would be installed in most modern houses, it is now possible to use high efficiency, time controlled, fully automatic boilers for boat and water heating.

As boaters we are not alone in facing a relentless list of increasing costs, a similar situation is impacting on the land based scene as consumers are faced with ever increasing costs coming at them from all angles.

To mitigate slightly the land based energy cost increases, consumers are turning more and more to wood fired stoves.

A good stove, correctly fitted and positioned, can provide up to half of the heat required to keep an average sized home warm, this can be a major cost saver and provide a good model for boaters to follow.

This set up of a high efficiency economical major heat source together with a fail safe back up should cover most eventualities with the back up providing a means of keeping warm, boiling water and limited cooking. Some boaters are putting all their eggs in one basket and when it goes wrong there is no backup.

If we are going to follow this model it is extremely important to make sure that we get the chimney system spot on as we can't provide the 10 metres of flue height which is available in most two story houses.

The chimney height available to boaters depends upon what type of boat we are going to fit it in, generally narrowboats are always vertically challenged.

In order for the stove to function correctly, most stove manufacturers will call for a minimum flue height of 4.5 metres (15ft) or they will specify a minimum and maximum chimney vacuum which must be attainable under all conditions.

(Chimney vacuum is generally measured in negative ins water gauge or negative millibars. Qualified land based installers are HETAS registered, any HETAS registered installer would have a flue vacuum gauge and know how to use it for both flue vacuum readings and fault finding.)

Whoever is installing the appliance, must always check that this information is provided by the manufacturer in the technical manual supplied with the appliance.

If it is not possible to provide the flue height or chimney vacuum specified by the manufacturer, then the appliance should not be fitted in a boat, if it is and there are any problems the manufacturer will say that the appliance has not been fitted in line with our instructions, and decline to accept any responsibility whatsoever.

As insurers learn more about this situation they too will use it to refuse making claim payments and the claim will then be placed on the installers doorstep.

If you are in any doubt check it out and get it in writing from the appliance manufacturer.

The power, suck or vacuum the chimney can develop depends upon the following:-

- **ITS HEIGHT.**
- **ITS DIAMETER.**
- **THE TEMPERATURE OF THE GASSES IN IT.**
- **THE RESISTANCE OF THE INNER SURFACE OF THE FLUE PIPE OR PIPES.**
- **LOCATION OF MOORING**
- **THE PROVISION OF ADEQUATE VENTILATION IN THE VESSEL**

It is obvious that on a boat the first and second requirements are in short supply, we normally have low flues, which are small in diameter and generally not very well insulated.

Any bend in any part of the chimney roughness on the internal chimney wall will slow down the velocity of rising gasses and reduce the effectiveness of the chimney.

Any slight reduction in the flue gas temperature will reduce the chimney vacuum or pull, hence when the stove is slowed down, the flue gas cools down, the chimney vacuum reduces and the stove could go out. This problem is highlighted even more during very cold weather when the external part of the chimney cools down even faster.

To improve the chimney performance of both oil and solid fuel appliances chimneys, we have added to our traditional deck flange system a new twin wall stainless steel above deck extension, this allows for high quality, fully insulated, stainless steel extensions to be fitted.

These systems are the same as those used on domestic applications, they have been in use for years and the performance is well established.

Rather than a taper fitting they are attached to the deck flange by a special bayonet type twist lock system, which is incorporated into our copyrighted deck flange system.

There is a series of Bubble Deck Flange Kits designed to -:

- 1. Allow accurate vertical alignment of the traditional chimney or twin wall stainless extensions irrespective of the roof curvature.**
- 2. Create a better fire stop distance from hot flue pipes.**
- 3. Provides a safer and neater way of getting a hot flue pipe through the inner and outer ceiling skin on a narrow boat, broadbeam boat or Dutch Barge.**
- 4. Provide a fully insulated above deck extension with a simple and secure fitting.**

Chimneys require a suitable firebreak from any combustible material and the traditional cast iron deck flange does not provide this.

The downward projecting socket on the old cast iron deck flange can come into contact with the flue pipe and in extreme cases where solid fuel stoves have been left with ash pit doors open, the heat from the overheated flue pipe can conduct into the cast iron and cause a serious fire hazard to combustible materials used in the roof construction and lining out process.

As can be seen in Fig 1 The Bubble deck flange assemblies -:

Keep the flue pipe away from the deck flange.

Create a fire stop from foam, roof panel fixing battens or roof panels.

In houses the horizontal distance from an uninsulated flue pipe to any combustible is 2.5 times the diameter of the flue pipe. The horizontal distance from approved twin wall flue pipe to combustible is 50mm

(See Part J of the building regulations.)

The latest Bubble Deck Flange kit comprises of all the components detailed in fig 1 and it is generally supplied as kit or in separate pieces if required.

FIG 1 ASSEMBLY DETAILS

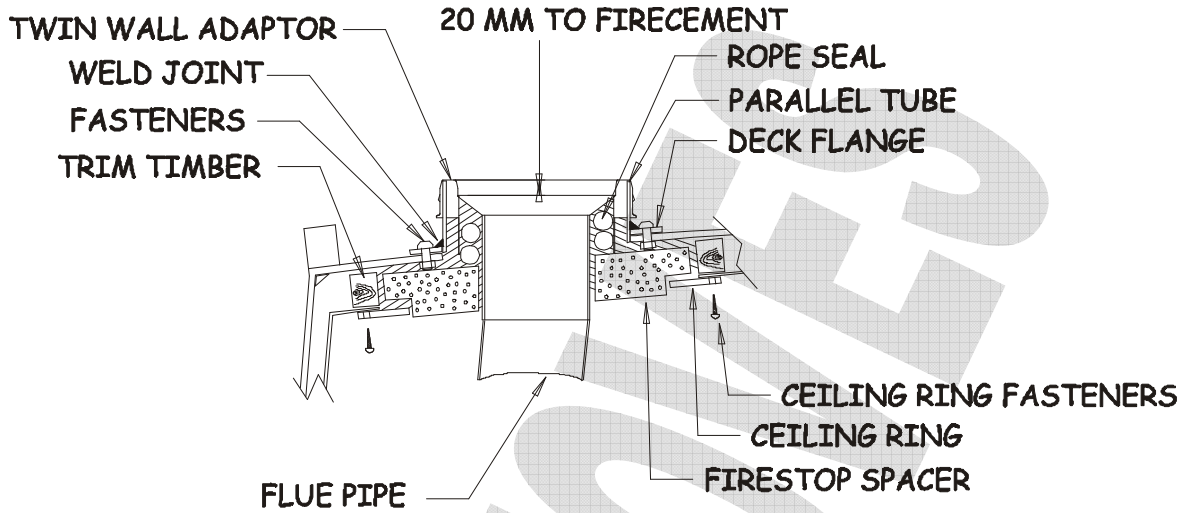

ADDITIONAL INFORMATION

http://www.oilstoves.co.uk/webdocs/technical/Bubble/Bubble_Corner_Solid_Fuel_Installation_Instructions.pdf

http://www.oilstoves.co.uk/webdocs/prices/BUBBLE_Marine_Solid_Fuel_Stoves_August_06.pdf

http://www.oilstoves.co.uk/webdocs/technical/Bubble/Bubble_Corner_Solid_Fuel_User_Instructions.pdf

THE DANGERS OF CARBON MONOXIDE

www.opdm.gov.uk/building-regulations